

JACKSONVILLE - FLORIDA

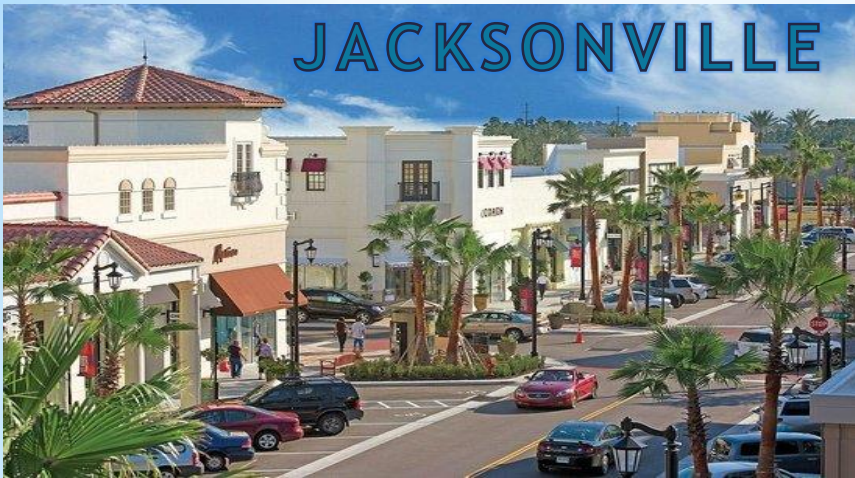

JACKSONVILLE

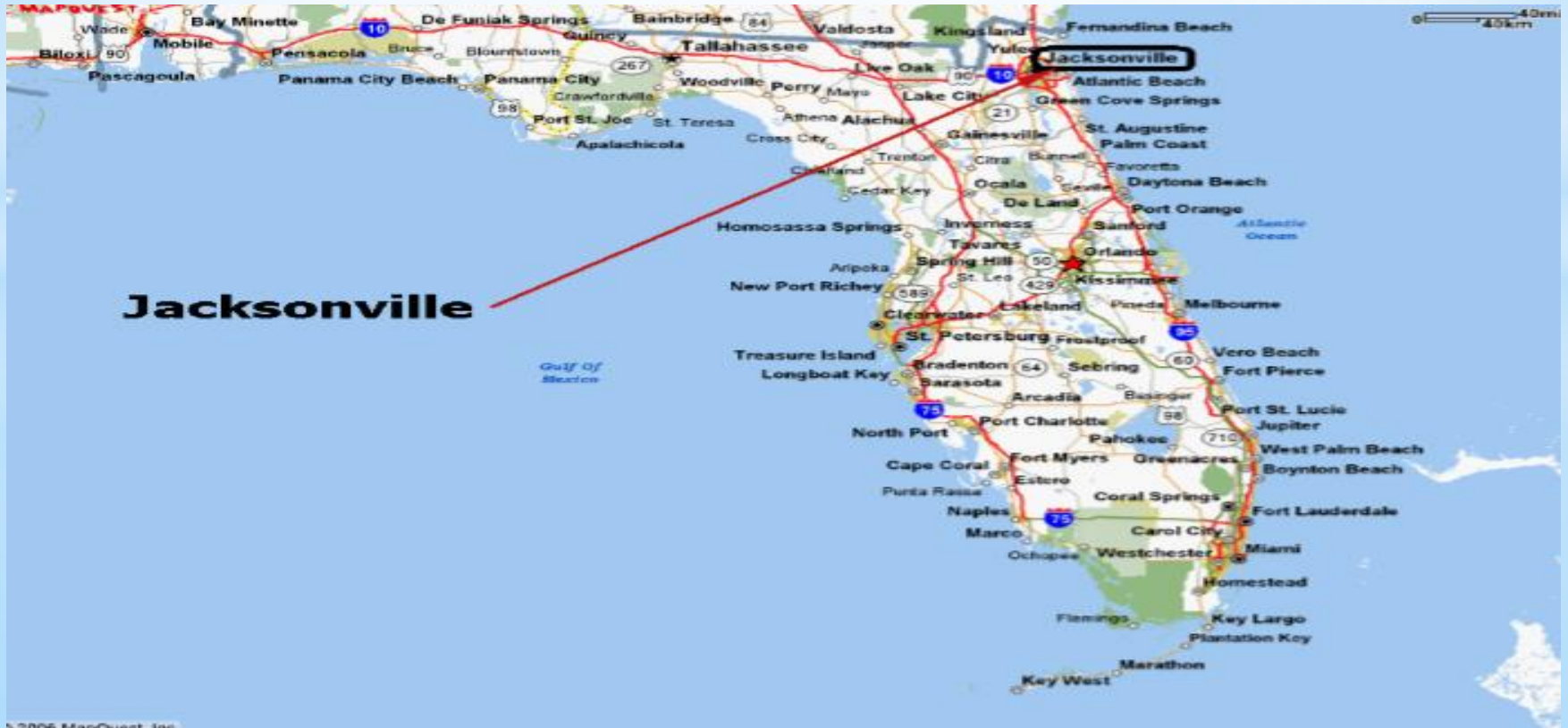

2285 BRIAN LAKES DR.

2285 BRIAN LAKES E DRIVE JACKSONVILL FLORIDA



INCOM & EXPENSES

PURCHES PRICE	\$142,000
RENOVATION COSTS	\$6,000
TOTAL COSTS	\$148,000
SELL PRIC	\$165'000
PURCHES DATE	26/09/2017
SELL DATE	20/11/2017
NET INCOM	\$17,000
ROI	10.3%

Bird view



NEIGHBORHOOD PICTURES

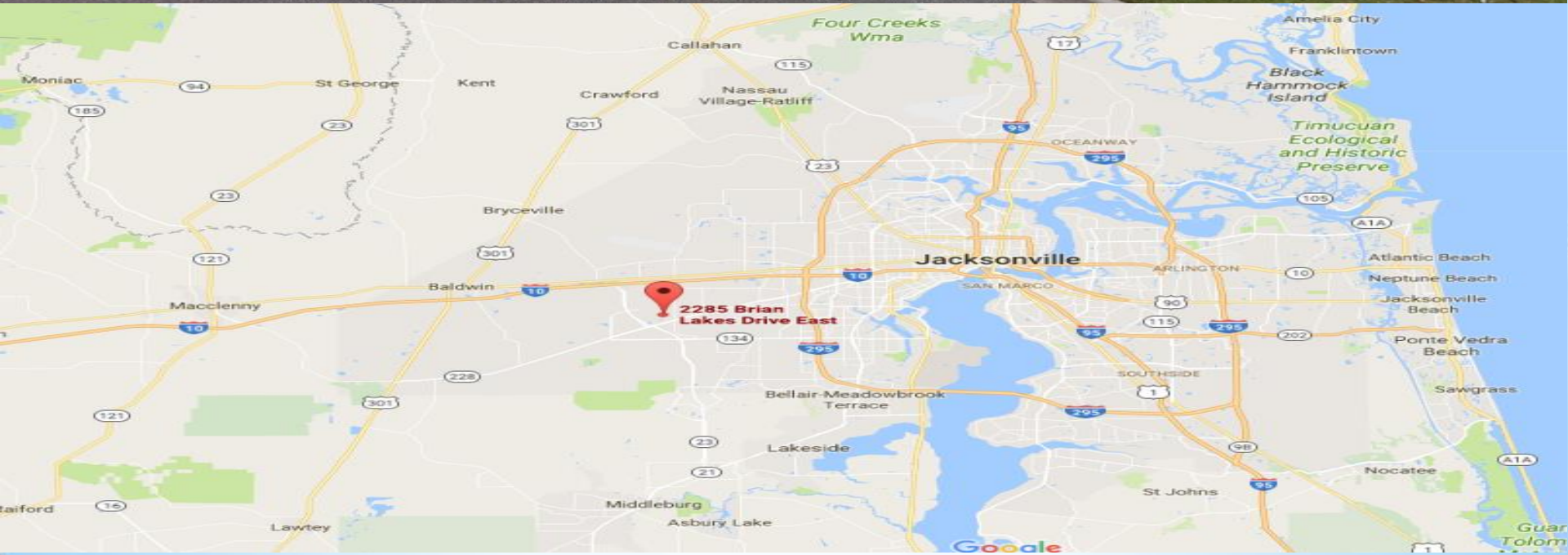

Front view



HOME PICTURES

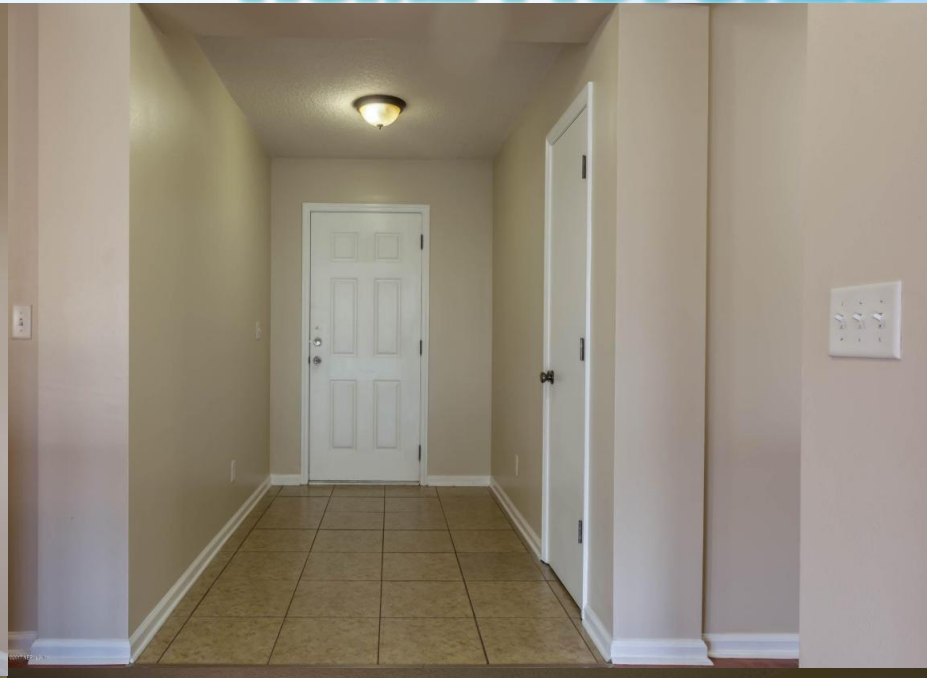

HOME PICTURES









SALES COMPARABLE

15 miles radius

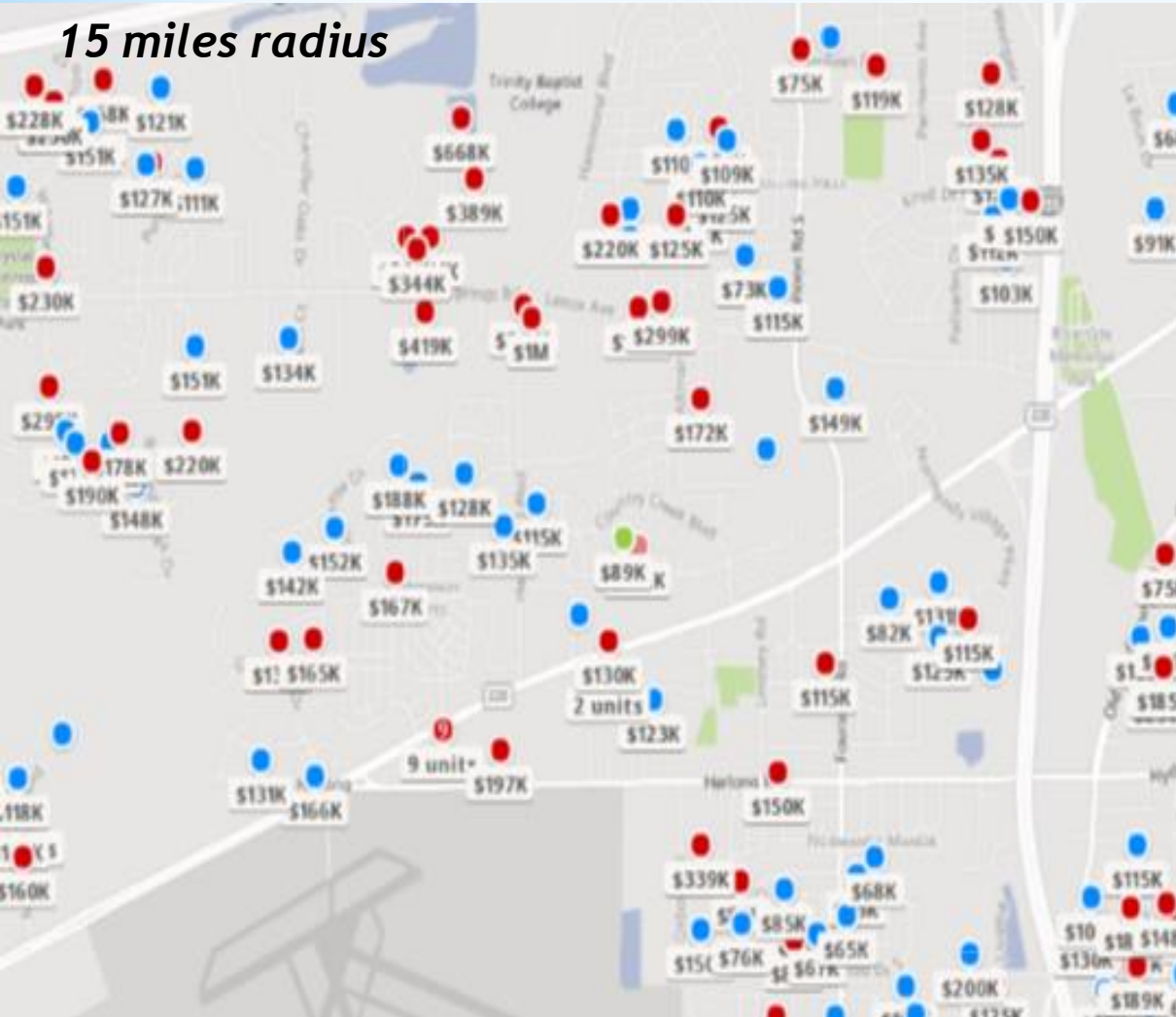

26 photos

HOUSE FOR SALE
\$150,000 3 bds . 2 ba . 1,533 sqft
2 days on Zillow - 8102 Wormwood Rd, Jacksonville, FL

41 photos

HOUSE FOR SALE
\$135,000 4 bds . 2 ba . 1,613 sqft
2 days on Zillow - 2154 Hugh Edwards Dr, Jacksonville, FL

10 photos

FOR SALE BY OWNER
\$138,900 3 bds . 2 ba . 1,635 sqft
9 days on Zillow - 2034 Figaro Ln, Jacksonville, FL

SALES COMPARABLE



10 photos

HOUSE FOR SALE
\$150,000 3 bds · 2 ba · 1,300 s..
↑ \$2,000 (May 19) · 8515 Lenox Ave, Jackson...
MURPHY REALTY

Video walkthrough

HOUSE FOR SALE
\$148,000 3 bds · 2 ba · 1,400 s..
↑ \$7,000 (Apr 21) · 2039 Firestone Rd, Jacks...

35 photos

HOUSE FOR SALE
\$176,500 3 bds · 2 ba · 1,895 s..
12 days on Zillow · 517 Portobello Dr, Jackson...
REDZONE REALTY LLC

SALES COMPARABLE

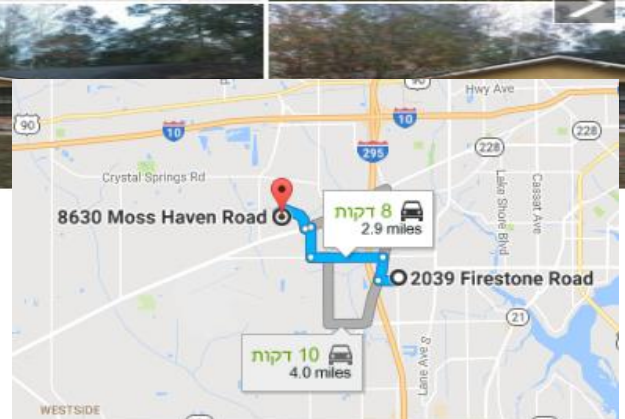
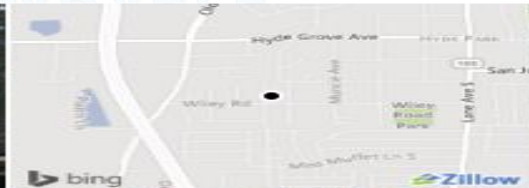

**2039 Firestone Rd,
Jacksonville, FL 32210**



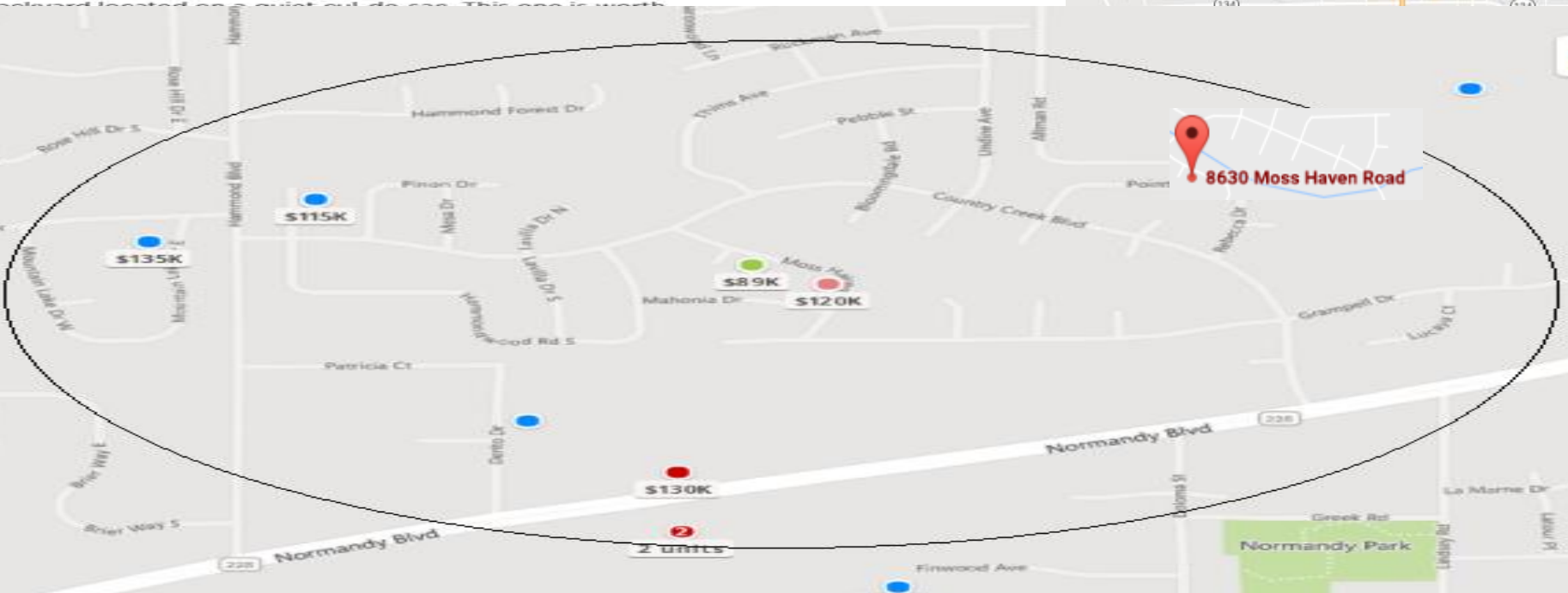

3 beds · 2 baths · 1,400 sqft

This home is an absolute must see! Completely renovated with special attention to detail. Granite countertops in the kitchen, bamboo floors, beautiful stone accents in the family room and modern light fixtures! This home is simply gorgeous, with a huge backyard located on a quiet cul-de-sac. This one is worth

FOR SALE
\$148,000
Price cut: -\$7,000 (4/21)
Zestimate®: \$145,866
EST. MORTGAGE
\$558/mo
Get pre-qualified



CRIME REPORT

-  Calculate your commute time from this home ▼
-  Tremendous BBQ, Winn-Dixie, Green Acres Sporting ... ▼
-  See demographics within 1 mile of this home ▼
-  See 3 schools assigned to this home. Crystal Springs El... ▼
-  See reported crimes near this home ▲

Date	Type	Description
05/15/2017	Other	DISPUTE. (This report is from Jacksonville Sheriff's Office completed dispatched (911) calls for service call log. Information may be subject to change.)
05/15/2017	Other	DISPUTE. (This report is from Jacksonville Sheriff's Office completed dispatched (911) calls for service call log. Information may be subject to change.)
05/15/2017	Other	SUSPICIOUS PERSON. (This report is from Jacksonville Sheriff's Office completed dispatched (911) calls for service call log. Information may be subject to change.)

Data provided by SpotCrime.com and CrimeReports.com.

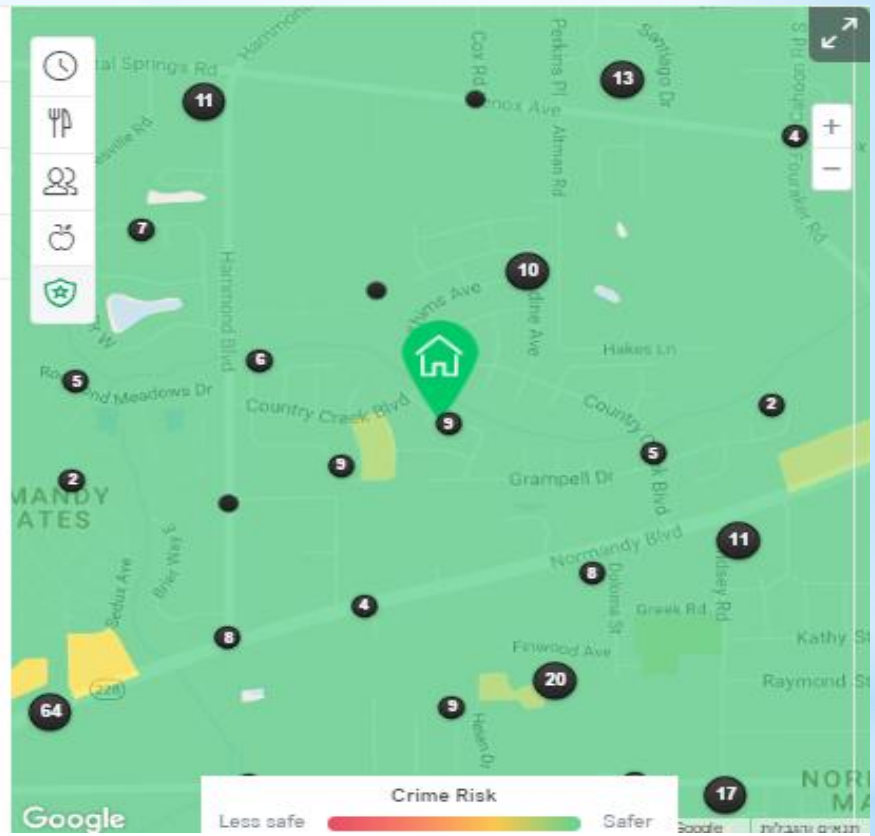

Property appraiser

Tax Account Details

Account	Property Type	Year
008806-0612	REAL ESTATE	2016

Mailing Address:

BASHAM EULA I
8630 MOSS HAVEN RD
JACKSONVILLE, FL
32221

SITUS:

8630 MOSS HAVEN RD 32221

Exemptions

HX 25000
WF 500
HB 25000

Millage Code

GS

Escrow Code

TDA Number

0

Status Code

Status Message

Legal Description

35-45 27-25-25E COUNTRY CREEK UNIT THREE LOT 16 BLK 11

Element	Code	Detail
Exterior Wall	15	15 Concrete Blk
Exterior Wall	19	19 Common Brick
Roof Struct	3	3 Gable or Hip
Roofing Cover	3	3 Asph/Comp Shng
Interior Wall	4	4 Plywood panel
Int Flooring	12	12 Hardwood
Int Flooring	11	11 Cer Clay Tile
Heating Fuel	4	4 Electric
Heating Type	4	4 Forced-Ducted
Air Cond	3	3 Central

Element	Code	
Stories	1.000	
Bedrooms	4.000	
Baths	2.000	
Rooms / Units	1.000	

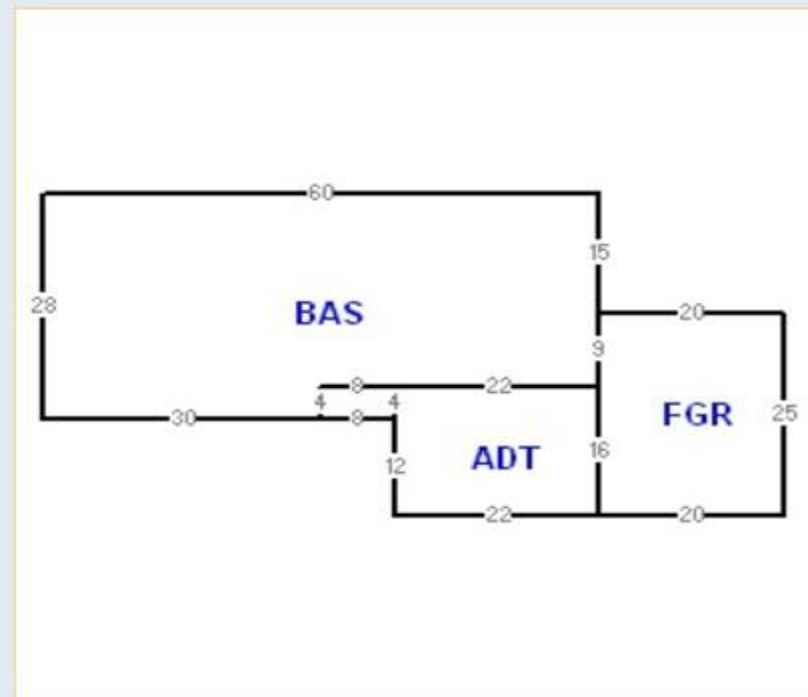

Tax property

Tax Account Details

Account	Property Type	Year
008806-0612	REAL ESTATE	2016

Mailing Address:

BASHAM EULA I
8630 MOSS HAVEN RD
JACKSONVILLE, FL
32221

SITUS:

8630 MOSS HAVEN RD 32221

Exemptions

HX 25000
WF 500
HB 25000

Millage Code

GS

Escrow Code

TDA Number

0

Status Code

Status Message

Legal Description

35-45 27-25-25E COUNTRY CREEK UNIT THREE LOT 16 BLK 11

Ad Valorem Taxes						
Taxing Code	Taxing Authority	Assessed Value	Exemption Amount	Taxable Value	Millage Rate	Taxes
1001	CITY OF JACKSONVILLE	\$91,614.00	\$50,500.00	\$41,114.00	11.44190	\$470.42
2001	ST JOHNS RIVER WTR MGMT DIST	\$91,614.00	\$50,500.00	\$41,114.00	0.28850	\$11.86
4001	FL INLAND NAVIGATION	\$91,614.00	\$50,500.00	\$41,114.00	0.03200	\$1.32
6000	USD	\$91,614.00	\$50,500.00	\$41,114.00	0.00000	\$0.00
7001	SCHOOLS	\$91,614.00	\$25,500.00	\$66,114.00	6.80200	\$449.70
Total					18.5644	\$933.30

Non Ad-Valorems

Non-Ad Valorem Assessments		
Levying Code	Levying Authority	Taxes
SOLW	SOLIDWASTE	\$151.80
STMW	STORMWATER	\$60.00
Total		\$211.80

If Paid By

Taxes	Fees	Interest	Discount	If Paid By	Amount Due
\$1,145.10	\$0.00	\$0.00	(\$22.90)	3/31/2017	\$0.00

Payment History

Date Paid	Receipt Year	Receipt	Paid By	Paid
1/31/2017	2017	7001408.0001		\$1,122.20

Unpaid Tax Certificates

No Records Found